

MY MEASUREMENTS - WWW.SEWYOUMAGAZINE.COM

NAME:

DATE:

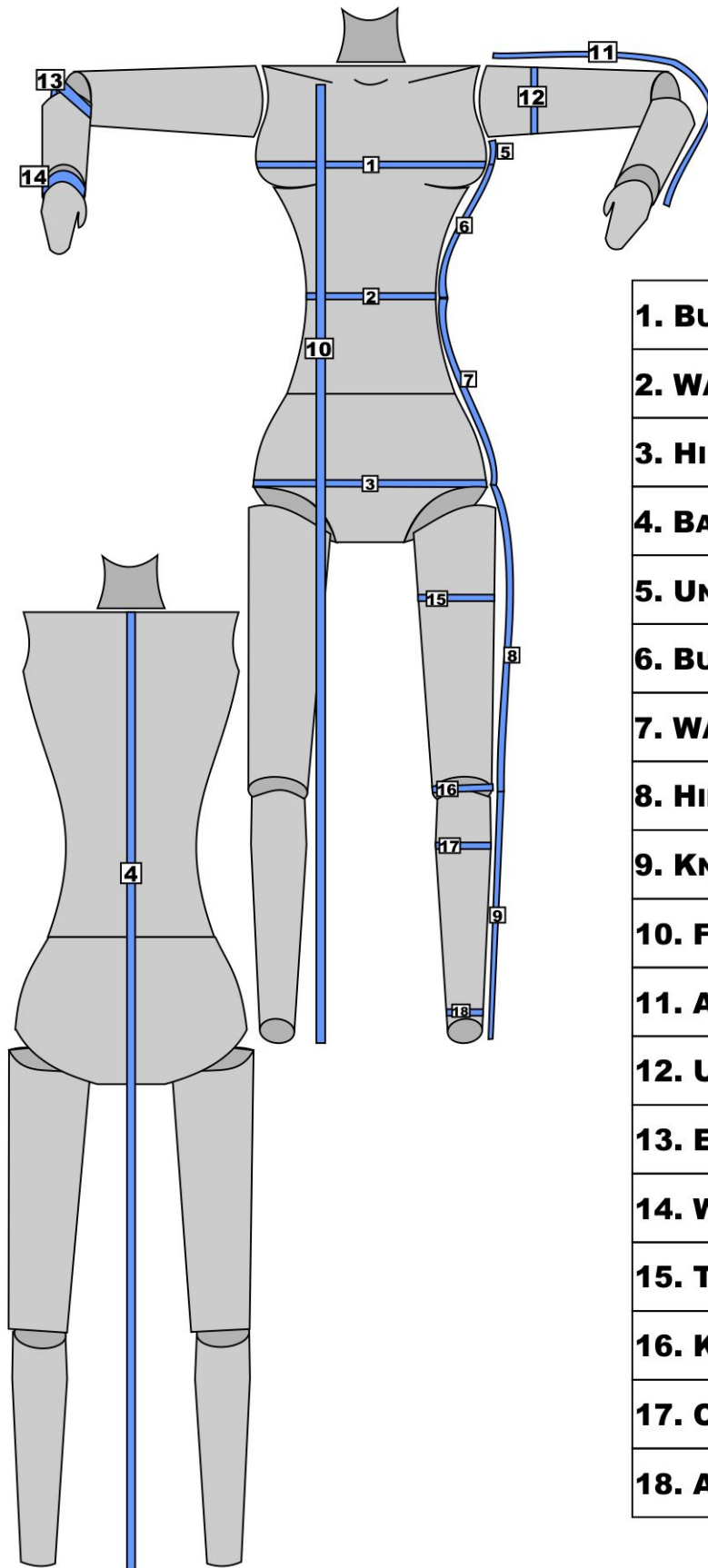

1. BUST:

2. WAIST:

3. HIPS:

4. BACK LENGTH:

5. UNDERARM TO BUST:

6. BUST TO WAIST:

7. WAIST TO HIP:

8. HIP TO KNEE:

9. KNEE TO ANKLE:

10. FRONT LENGTH:

11. ARM LENGTH:

12. UPPER ARM:

13. ELBOW:

14. WRIST:

15. THIGH:

16. KNEE:

17. CALF:

18. ANKLE:

NAME:

DATE:

ARM POSITIONS

FOR MEASURING BUST

FOR MEASURING ARM LENGTH

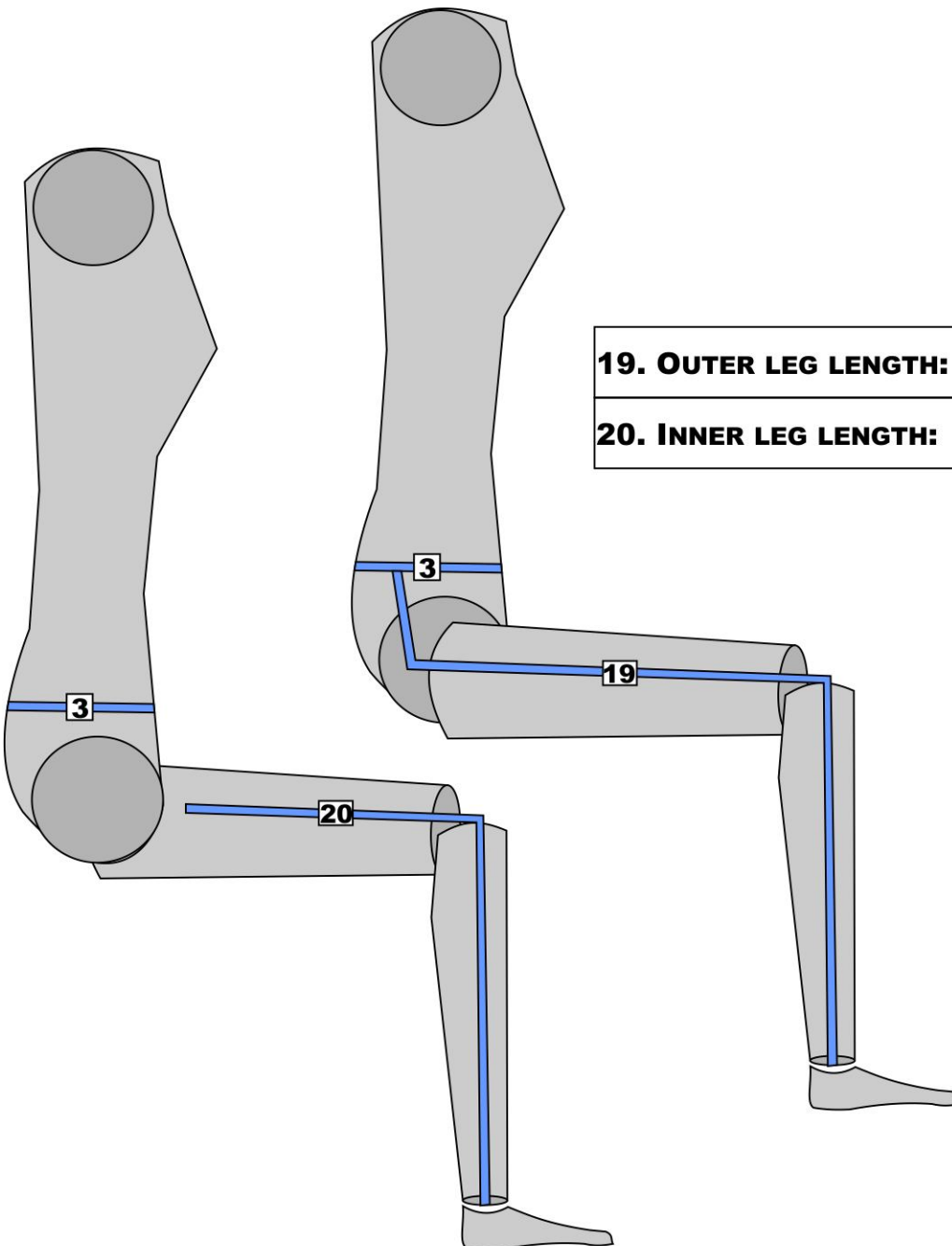
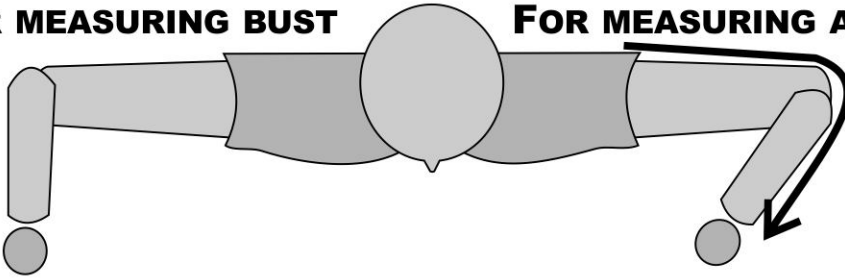

19. OUTER LEG LENGTH:

20. INNER LEG LENGTH: